

# A&G MANUFACTURING CO., INC.

YOUR SOURCE FOR QUALITY, SERVICE AND EFFICIENT BUYING.

PHONE 978-587-2859

WWW.AGMFG.NET

1-888-367-8227

## SERIES 1015 (12" HIGH) HEAVY DUTY VALVE BOX GREEN

**60 PER PALLET**

- BODY WITH STD. DROP-IN COVER
- BODY WITH "T" COVER
- BODY W/METER READER COVER
- BODY W/CAPTIVE HINGED COVER
- BODY

1015-1G2G	10.00 LBS.	4.53 KG
1015T-1G2G	9.97 LBS.	4.52 KG
1015-1G3G	10.13 LBS.	4.49 KG
1015-1G4C	10.50 LBS.	4.76 KG
1015-1G	7.73 LBS.	3.50 KG

- 1. STD. DROP-IN COVER
- 2. "T" COVER
- 3. COVER WITH METER DOOR
- 4. CAPTIVE HINGED COVER

1015-2G	2.27 LBS.	1.03 KG
1015T-2G	2.24 LBS.	1.02 KG
1015-3G	2.18 LBS.	.99 KG
1015-4G	2.77 LBS.	1.26 KG



1015-1G  
BODY



1.  
1015-2G  
STD DROP-IN  
COVER



2.  
1015T-2G



3.  
1015-3G  
COVER  
WITH  
METER  
DOOR



4.  
1015-4G

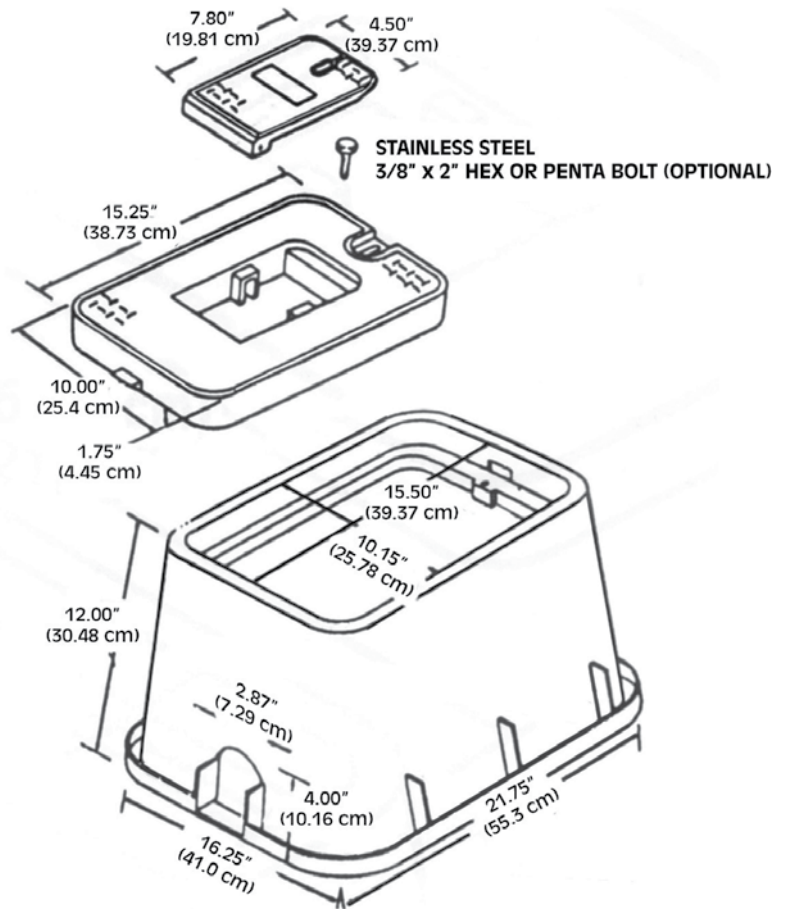

### SPECIAL FEATURES

- HEAVY DUTY CONSTRUCTION
- MOLDED IN NYLON NUT FOR BOLT
- UV INHIBITOR TO PREVENT DISCOLORING & CRACKING
- NESTABLE FOR STORAGE OR SHIPPING

### OTHER STOCK COLORS AVAILABLE

- BLACK
- GRAY
- LAVENDER
- TAN

**STANDARD MARKINGS AVAILABLE: IRRIGATION CONTROL VALVE • WATER (solid or meter door) • SEWER • ELECTRIC • RECLAIMED WATER • CATV • TELEPHONE • BLANK**